

DESCRIPTION

MT7813 is a high precision LED constant current control chip operating at critical conduction mode (CRM) with zero current switched-on and peak current switched-off. It's mainly targeted for non-isolated buck LED power systems.

Critical conduction mode ensures that the MT7813 turns on the internal power MOSFET when the inductor current reaches zero, reducing the power MOSFET switching loss, the system achieves more than 95% efficiency. With critical conduction mode, and the input compensation, MT7813 outputs high accuracy LED current, and further achieves good line regulation and load regulation.

MT7813 embedded with internal power MOSFET, simplify the peripheral circuits. Low BOM cost is achieved.

MT7813 has wide working voltage range, which is suitable for full-range AC input or 10V-400V DC input voltage. MT7813 provides various kinds of protections, such as over current protection(OCP), short circuit protection (SCP), over voltage protection (OVP) and over temperature protection(OTP), etc, to ensure system reliability.

FEATURES

- Critical Conduction Mode, not sensitive to the inductance.
- Up to 95% of efficiency
- Highly accurate constant LED current
- Cycle-by-cycle current limitation
- LED Short Circuit Protection
- LED Over Voltage Protection
- Leading edge blanking technique
- Under-voltage lockout (UVLO) protection
- Over temperature protection
- SOP8/ DIP7 package

APPLICATIONS

- LED bulb, LED tube, LED signal and landscape lamp
- LED stage light, LED candle light, LED corn light, etc
- General purpose constant current source

Typical Application Circuit

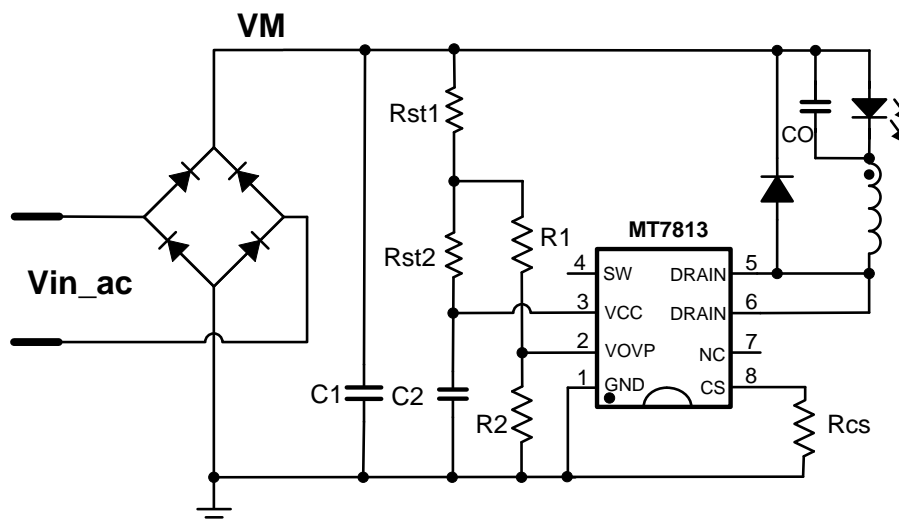

ABSOLUTE MAXIMUM RATINGS

VCC maximum sink current	5mA
VOVP (over voltage protection pin)	-0.3 ~ 6V
DRAIN (internal high-voltage power MOS drain)	-0.3V ~ 500V
SOURCE (internal high-voltage power MOS source)	-0.3 ~ 40V
CS (current detection pin)	-0.3V ~ 6V
P _{DMAX} (maximum power consumption)	0.8W (SOP8); 1.2W (DIP7)
Storage Temperature	-55°C ~ 150°C
Junction Temperature (T _j)	150°C

RECOMMENDED OPERATING CONDITIONS

Operating Temperature	-40°C ~ 105°C
Output Current (SOP8)	<300mA
Output Current (DIP7)	<360mA

ORDERING INFORMATION

Device	Package
MT7813S	SOP8
MT7813D	DIP7

PIN CONFIGURATIONS

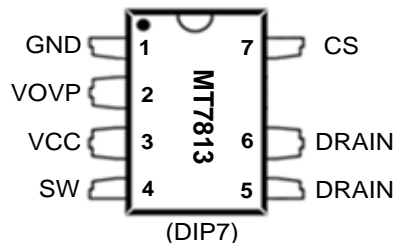
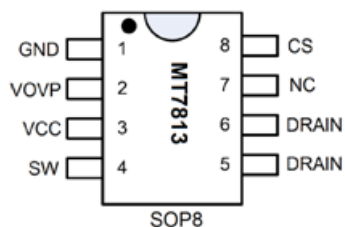

Chip Mark

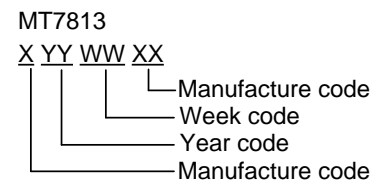

PIN DESCRIPTION

Name	Pin No. SOP8	Pin No. DIP7	Description
GND	1	1	Ground
VOVP	2	2	Over voltage protection and line voltage compensation configuration
VCC	3	3	Chip power supply, internal clamped at 15.5V
SW	4	4	Internal high-voltage power MOS source
DRAIN	5/6	5/6	Internal high-voltage power MOS drain
NC	7		Floating
CS	8	7	Current sense input, connect a sense resistor to ground

ELECTRICAL CHARACTERISTICS

(Test condition: VCC=13V, TA=25°C unless otherwise stated.)

Symbol	Parameter		Min	Typ	Max	Unit
Start-up and supply voltage (VCC Pin)						
I _{START}	Start up current	V _{CC} < V _{CC_UV}		60	150	μA
V _{CC_UV}	Lower threshold Voltage of V _{CC} (UVLO)	V _{CC} Pin ramp down		5.5		V
V _{START}	Start-up voltage	V _{CC} Pin ramp up		12		V
V _{CC-CLAMP}	V _{CC} Clamping voltage	I _{DD} <5mA		15.5		V
Supply current						
I _{op}	Operating current			0.3		mA
Current sense (CS Pin)						
V _{CS-TH}	Peak current detection threshold		390	400	410	mV
LEB1	Leading edge blanking at CS pin			500		ns
Thermal Protection						
OTP	Over temperature protection			155		°C
	Over temperature release hysteresis			30		°C
Driver Circuit						
T _{OFF_MIN}	Minimum OFF time			1.5		us
T _{OFF_MAX}	Maximum OFF time			400		us
T _{ON_MAX}	Maximum ON time			55		us
High-voltage Power MOSFET (DRAIN/SOURCE)						
R _{DSON}	Static drain-source on-resistance	V _{GS} =13V/I _{DS} =1.25A		5.5		Ω
BV _{DSS}	Drain-source breakdown voltage	V _{GS} =0V/I _{DS} =250uA	500			V

BLOCK DIAGRAM

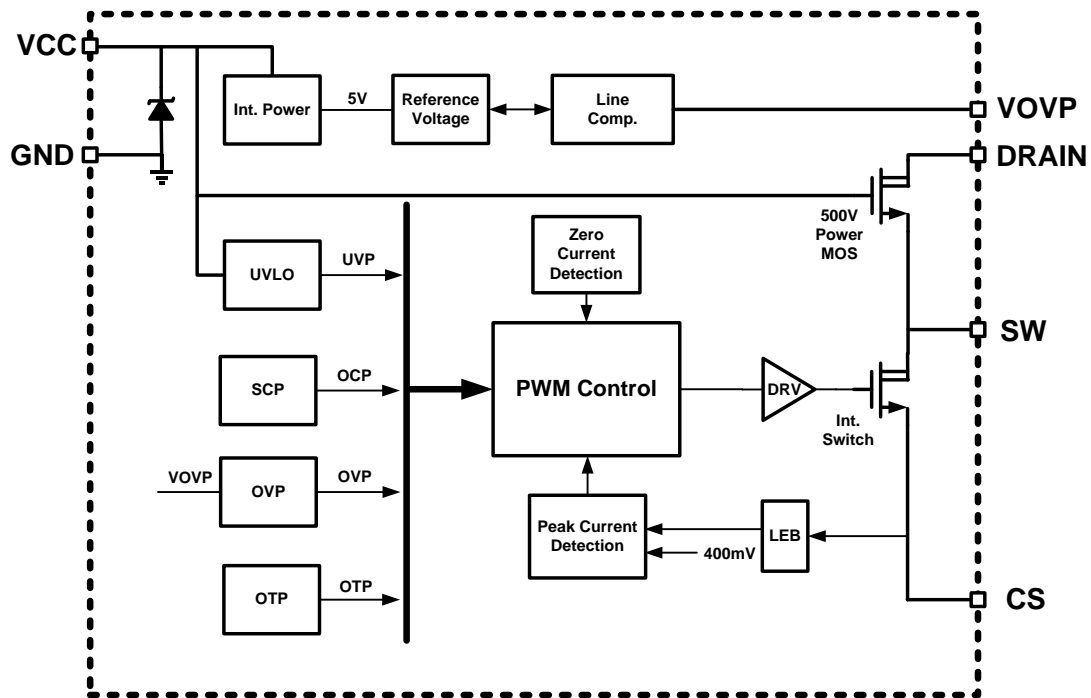

APPLICATION INFORMATION

MT7813 is a constant current driver with built-in 500V power MOSFET. It works in critical conduction mode, switches on the power MOSFET at zero inductor current, this way improves efficiency and reduces the power MOSFET switching loss. MT7813 is specially designed for LED lighting applications, simplified peripheral circuits and low BOM cost is achieved.

Start up

When power on, VCC is charged through the start-up resistor. As VCC reaches 12V, the control logic starts to work, and internal switch starts toggling. When VCC raise up to 15.5V, it will be clamped. MT7813 shuts down as VCC falls below 5.5V.

CRM and Output Current Setup

Internal switch current is cycle-by-cycle detected by monitoring the CS pin voltage. When the voltage on CS pin reaches 400mV (internal

reference voltage), the internal power MOSFET is turned off. When the inductor current drops to zero, the system turns on the internal power MOSFET again.

The peak inductor current is given by:

$$I_{LPK} = \frac{400}{R_{CS}} (mA) \quad (1)$$

Where R_{CS} is the current sense resistor in ohm. The CS comparator also includes a 500ns leading edge blanking time to block the transient noise as the power switch just turned on.

The current in LED can be calculated as:

$$I_{LED} = \frac{I_{LPK}}{2} = \frac{400mV}{2 \times R_{CS}} (mA) \quad (2)$$

Where I_{LPK} is the peak inductor current. Shown in the above equation, the output current is determined by the R_{CS} and the 400mV reference voltage, insensitive to the inductance of the inductor.

Switching Frequency

MT7813 operates at critical conduction mode. When the inductor current is zero, the system turns on the internal switch, in result, the high-voltage power MOSFET is also turned on, inductor current rises from the ground up. The power MOSFET conduction time is:

$$T_{ON} = \frac{L \times I_{LPK}}{V_{IN} - V_{LED}} \quad (3)$$

Where L is the inductance of the inductor; I_{LPK} is peak current through the inductor; V_{IN} is the DC voltage of the rectified input voltage; V_{LED} is the forward voltage drop on the LED.

When the CS voltage increases to the 400mV, the internal switch is turned off, in result, the internal power MOSFET is also switched off. The inductor current will discharge the LED through the free-wheeling diode. The internal switch won't turned on until the current in the inductor drops to zero. The power MOSFET turn-off time is:

$$T_{OFF} = \frac{L \times I_{LPK}}{V_{LED}} \quad (4)$$

Operating frequency of the system is:

$$f = \frac{1}{T_{ON} + T_{OFF}} = \frac{V_{LED} \times (1 - \frac{V_{LED}}{V_{IN}})}{L \times I_{LPK}} \quad (5)$$

From the above equation, it's showing that MT7813 operating frequency is determined by the input voltage V_{IN} , the LED forward voltage drop V_{LED} and the inductance L. The higher the input voltage V_{IN} , the higher the operating frequency. For both EMI and efficiency consideration, the operating frequency located between 30kHz -80kHz is recommended. To meet this requirement, appropriate inductance value should be determined at minimum input voltage condition.

MT7813 sets the maximum off-time $T_{OFF_MAX}=400\mu s$, the minimum off-time

$T_{OFF_MIN}=1.5\mu s$. Shown in T_{OFF} equation, if the inductance is large, T_{OFF} maybe longer than T_{OFF_MAX} , the system will turn on the switch before the inductor current falls to zero, after five times consecutive T_{OFF_MAX} cycles, the system enters hiccup and re-start status. On the contrary, if inductance is small, T_{OFF} may be shorter than T_{OFF_MIN} , then the inductor current has already been reduced to zero before the next cycle starts, the system enters into discontinuous mode. The actual LED current will be smaller than the target value.

Maxic Technology Corporation provides software design tool of this chip, it helps customer to come out proper solution and to choose the right inductance value.

LED Over voltage protection setup

MT7813 sets the Over voltage protection threshold by VOVP pin (Pin2). The external R1 and R2 form a resistive voltage divider.

Over voltage protection threshold is:

$$V_{OVP} = 0.90 \times \frac{R1}{R2} \quad (6)$$

R2 resistance is between 2.2kohm ~ 10kohm

(Refer to the following schematic. Equation (6) is based on the following assumptions: $R_{st1}=R_{st2}$, $R1 > R_{st1}$. R_{st1} and R_{st2} is about 200k ohms. R1 resistance is in 500k ohm range).

At the LED open circuit condition, once the output voltage exceeds the OVP threshold, MT7813 stops switching. Until the VCC voltage drops to UVLO threshold, the system restarts.

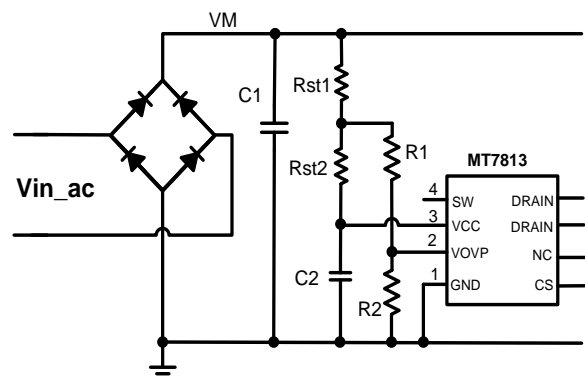

Consideration for OVP Setup:

- (1) Rst1 and Rst2 used as start-up resistors. Rst1=Rst2, so the input voltage VM is equally shared by these two resistors. At the middle point between Rst1 and Rst2, the input voltage VM is halved, and adopted for OVP threshold setup. Rst1 and Rst2 resistance is between 150k ohm ~ 400k ohms. If it needs to support lower input voltage, these two resistors should be smaller. On the contrary, these two resistors can be larger to improve efficiency.
- (2) Affected by the accuracy of resistor string Rst1, Rst2 and R1, R2, further affected by the accuracy of the chip internal reference voltage, the OVP threshold calculated by Equation (6) may not exactly matches the real value. The accurate OVP threshold can be achieved by adjusting the resistor R2. If the real OVP threshold is lower than expected, then the resistance of R2 should be decreased. On the contrary, the resistance of R2 should be increased. R2 initial value can be 4.7k ohms, then the resistance of R1 can be determined by Equation (6). Finally, fine tuning R2 to get accurate OVP threshold.
- (3) Highly recommended to set the Over voltage protection threshold at least 1.7 times of the maximum LED voltage. For example, the maximum LED voltage is 85V, the OVP threshold is better configured as $1.7 \times 85 = 144\text{V}$. If the 1.7 times maximum LED voltage still lower than 55V, then the OVP threshold should be set at 55V or higher.
It's not recommended to set the OVP threshold too close to the normal operating LED voltage. It may false trigger the OVP protection during normal operation, flickering occurs in result.
- (4) Once the inductance L is determined, Over voltage protection threshold (OVP) can't be set too high neither. If substitutes the OVP threshold into the Equation (4), the calculated

off-time T_{OFF} is less than the $T_{\text{OFF_MIN}}(1.5\mu\text{s})$, System will not work in critical conduction mode any more, but in discontinues conduction mode under open-circuit condition. In this case, the real OVP threshold will be much higher than the calculated threshold by Equation (6). In this case, it is recommended that the customers either lowering the Over voltage protection threshold or redesign the inductance to ensure that the OFF time (T_{OFF}) is greater than the $T_{\text{OFF_MIN}} (1.5\mu\text{s})$ under open-circuit condition.

Over-current Protection

MT7813 immediately turns off the internal switch and power MOSFET once the voltage at CS pin reaches 400mV. This cycle- by- cycle current limitation scheme prevents the relevant components, such as power MOSFET, transformer, etc. suffers from damage.

Other Protection Features

MT7813 provides various protections, such as LED short-circuit protection, current sense resistor open-circuit protection, current sense resistor short-circuit protection and over temperature protection, etc.

If it appears LED short-circuit and/or current sense resistor short-circuit condition, MT7813 immediately enters short-circuit protection status, ceasing switch toggling, discharging the VCC capacitor simultaneously. Finally, system gets into the hiccups-restart mode and consumes very low power. Once the short-circuit condition is removed, the system automatically resumes to normal working status.

Thermal protection circuit monitors the PN junction temperature. Once temperature exceeds the OTP threshold, MT7813 enters into protection status and suspends switching. If the temperature drops 30 degrees (in Celsius), MT7813 resumes toggling and back to normal status.

PCB Layout Consideration

- 1) The VCC (Pin3) de-coupling capacitor (typically 1uF ~ 4.7uF ceramic capacitor) must close to the pin (Pin3) as much as possible. Better not exceed 5mm. This can greatly improve the system noise immunity.
- 2) The Pin5, 6 are the drain of the high-voltage power MOSFET. They are the major noise disturbance source. The GND plane must fill underneath the chip to shield the drain terminal with other pins. Further, the GND plane underneath the chip must bare copper. Refer to the PCB layout example shown below.
- 3) The VOVP connection wire and the related resistor terminals must far away with the MOSFET drain (Pin5, 6). The connection wire should be as shorter as possible.

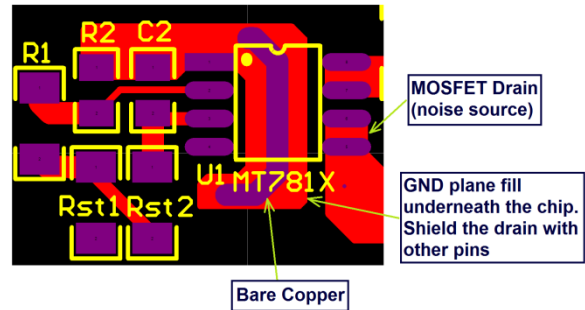

PACKAGE INFORMATION

SOP-8 PACKAGE OUTLINE AND DIMENSIONS

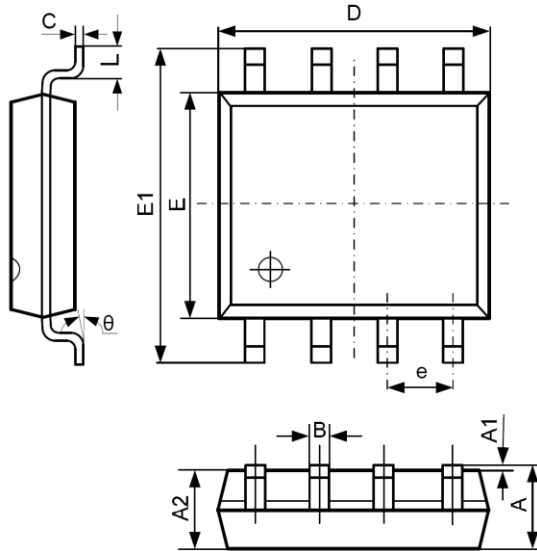

SYMBOL	DIMENSION IN MILLIMETERS		DIMENSION IN INCHES	
	MIN	MAX	MIN	MAX
A	1.350	1.750	0.053	0.069
A1	0.100	0.250	0.004	0.010
A2	1.350	1.550	0.053	0.061
B	0.330	0.510	0.013	0.020
C	0.190	0.250	0.007	0.010
D	4.700	5.100	0.185	0.201
E	3.800	4.000	0.150	0.157
E1	5.800	6.300	0.228	0.248
e	1.270 TYP		0.050 TYP	
L	0.400	1.270	0.016	0.050
θ	0°	8°	0°	8°

DIP7 PACKAGE INFORMATION

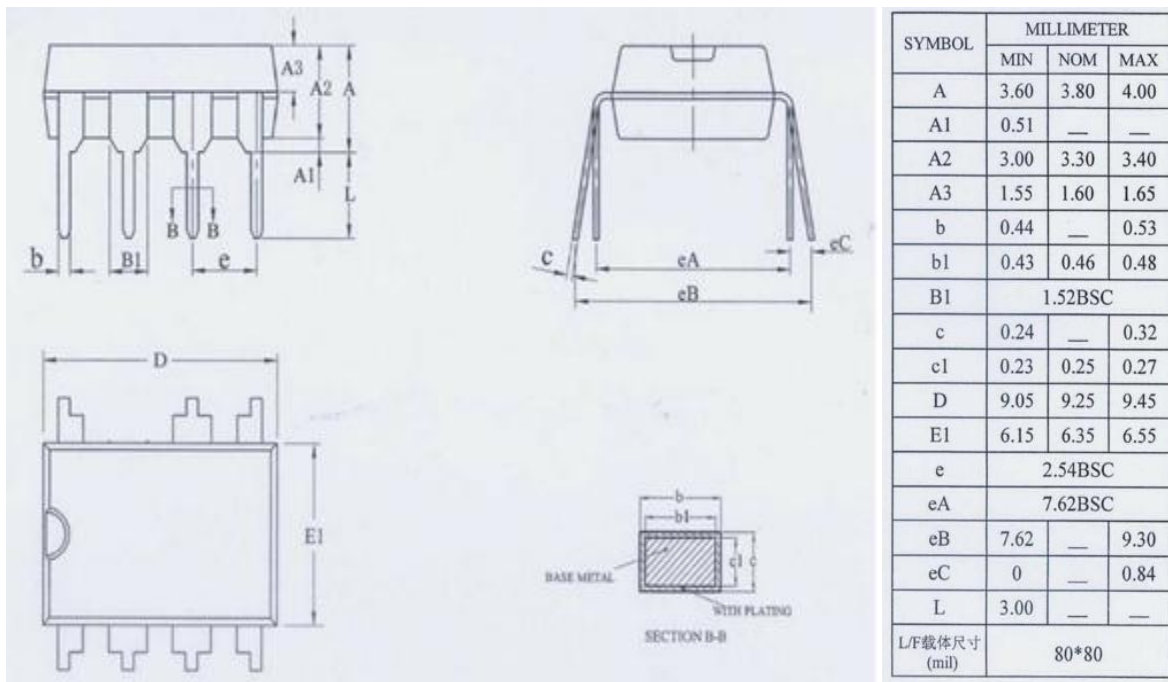

Important Notice

- Maxic Technology Corporation (Maxic) reserve the right to make correction, modifications, enhancements, improvements and other changes to its products and services at any time and to discontinue any product or service with notice. Customers should obtain the latest relevant information before placing orders and should verify that such information is current and complete. All products are sold subject to Maxic's terms and conditions of sale supplied at the time of order acknowledgement.
- Reproduction, copying, transferring, reprinting this paper without Maxic's written permission is prohibited.
- Maxic is not responsible or liable for customer product design by using Maxic components. To minimize the risks and associated with customer products and applications, customers should provide adequate design and operating safeguards and consult Maxic's sales department.