

DESCRIPTION

MT7968AL is a high precision primary-side feedback and regulation controller for LED lighting. It regulates precisely LED current in isolated lighting application. MT7968AL works under Discontinuous Conduction Mode (DCM). It simplifies LED lighting system by eliminating the secondary sense, the auxiliary winding and feedback circuit. Integrated with 600V power switch, the adjustable LED open-circuit voltage protection (OVP) function simplifies the system design and improves the reliability.

With Maxic's proprietary current regulation and internal compensation technique, the MT7968AL achieves $\pm 5\%$ accuracy of LED current along with excellent line regulation and load regulation. It is also non-sensitive to the inductance of the transformer.

MT7968AL provides various protection features to improve the system reliability, including over current protection (OCP), short circuit protection (SCP), over voltage protection (OVP) and over temperature protection(OTP),etc.

FEATURES

- Internal 600V power MOSFET
- No auxiliary winding
- Supporting 85V to 265V AC line voltage range
- Primary side sensing and regulation, no secondary side feedback
- High precision constant LED current ($\pm 5\%$)
- Adjustable LED open-circuit voltage protection threshold
- LED short circuit protection
- Cycle-by-cycle peak current control
- VDD under voltage lock-out protection
- Over temperature protection
- Available in DIP7 package

APPLICATION

- LED bulb, spotlight
- LED lighting application
- General purpose constant current source

Typical Application Circuit

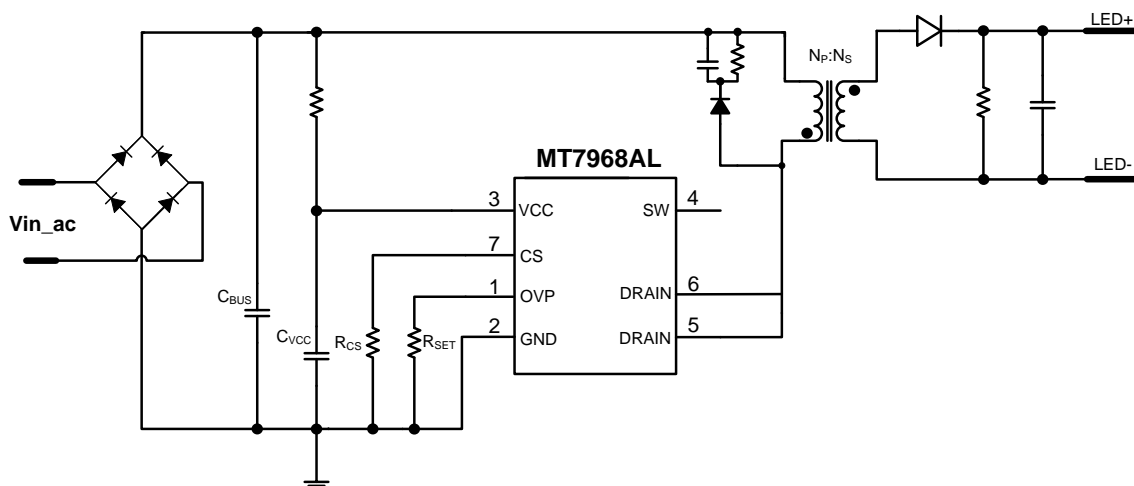

ABSOLUTE MAXIMUM RATINGS

DRAIN	-0.3V to 600V
VCC	-0.3V to 40V
VCC maximum sink current	5mA
OVP, CS	-0.3V to 6V
P _{DMAX} (Maximum Power)	1.2W
Storage Temperature	-55°C to 150°C
Junction Temperature (T _j)	150°C

Recommended operating conditions

Supply voltage	8V to 15V
Operating Temperature (Environment)	-40°C to 105°C

Thermal resistance

Junction to ambient (R _{θJA})	70°C/W
---	--------

PIN CONFIGURATIONS

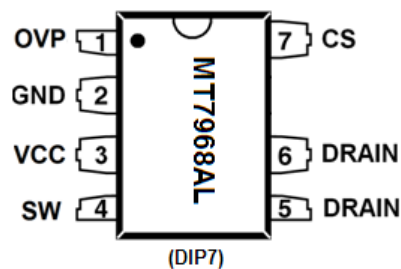

Chip Mark

MT7968AL
YY WW xxxx
 ———— Manufacture code
 ———— Week code
 ———— Year code

PIN DESCRIPTION

Name	Pin No.	Description
OVP	1	LED open-circuit voltage protection setting pin. Refer to <i>LED Open Circuit Protection</i> section.
GND	2	Ground
VCC	3	Power supply
SW	4	Internal power MOS source
DRAIN	5	Internal power MOS drain
	6	
CS	7	Current sense pin, a sense resistor is connected between CS and GND

ELECTRICAL CHARACTERISTICS

(Test conditions: $V_{CC}=12V$, $T_A=25^{\circ}C$ unless otherwise stated.)

Symbol	Parameter	Conditions	Min	Typ	Max	Unit
Start-up & Power supply (VCC Pin)						
I_{START}	Start-up Current			35	60	μA
UVLO	Under-voltage Lockup (Lower Threshold Voltage of V_{CC})	V_{CC} Pin ramp down		7		V
V_{START}	Start-up Voltage	V_{CC} Pin ramp up		13		V
$V_{CC-CLAMP}$	VCC clamp voltage	$I_{DD}=5mA$		15.5		V
Operation Current						
I_Q	Operation current			0.3		mA
Current Sense (CS Pin)						
V_{CS-TH}	Threshold Voltage of Peak Current Protection		485	500	515	mV
LEB1	Leading Edge Blanking at CS Pin			500		nS
Driver Circuit						
T_{OFF_MIN}	Minimum OFF time			2		μs
T_{OFF_MAX}	Maximum OFF time			240		μs
T_{ON_MIN}	Minimum ON time			1		μs
T_{ON_MAX}	Maximum ON time			24		μs
D_{DUTY_MAX}	Maximum Duty cycle			42		%
Over Temperature Protection						
OTP	Over temperature protection threshold			155		$^{\circ}C$
	Over temperature protection release thysteresis			20		$^{\circ}C$
Power MOSFET (DRAIN Pin)						
R_{DSON}	Drain-source turn on resistance	$V_{GS}=10V/I_{DS}=2A$		4		Ω
BV_{DSS}	Drain-source breakdown voltage	$V_{GS}=0V/I_{DS}=250\mu A$	600			V
I_{DSS}	Drain-source leakage current	$V_{GS}=0V/V_{DS}=600V$			10	μA

BLOCK DIAGRAM

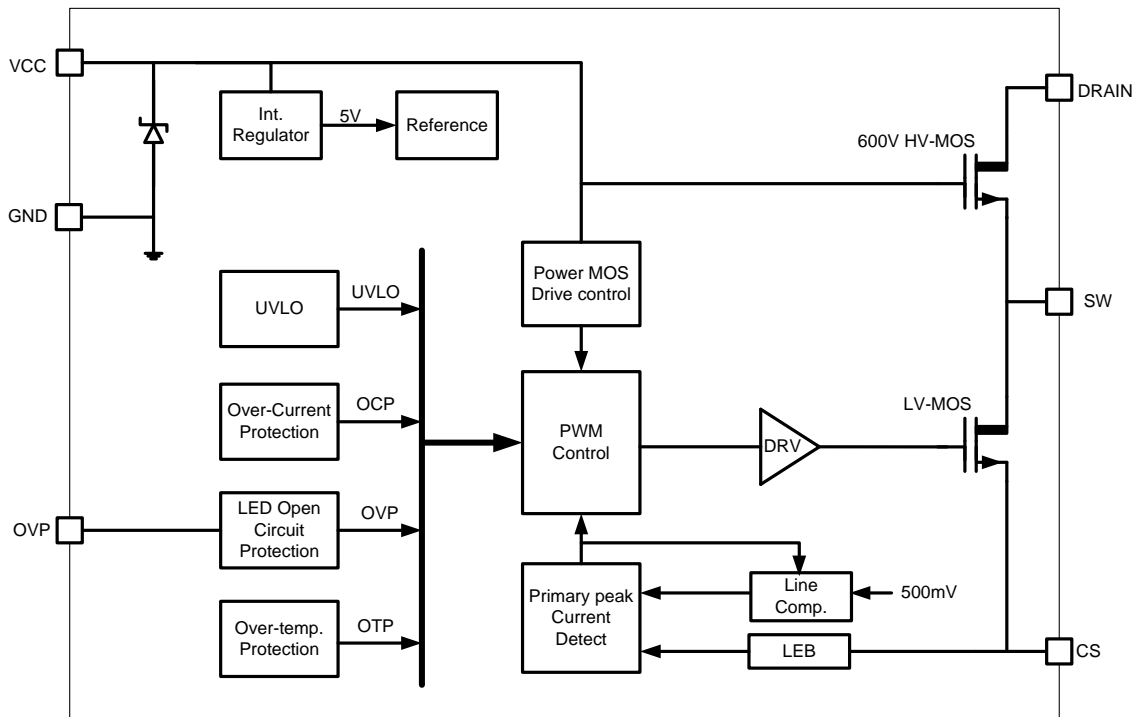

APPLICATION INFORMATION

MT7968AL is a high performance power switch specially designed for LED lighting. MT7968AL works in Discontinuous Conduction Mode (DCM). With Maxic’s proprietary constant current regulation and compensation technique, MT7968AL achieves accurate LED current output without auxiliary winding and secondary side feedback circuit. It integrates 600V power MOSFET, the total BOM cost is minimized with very few external components.

Start Up

During start-up, VCC is charged through a start-up resistor. As VCC reaches 13V, the control logic starts to work, and the power MOSFET begins to switch, as show in Fig.1. MT7968AL will shut down if VCC goes below 7V (UVLO threshold voltage).

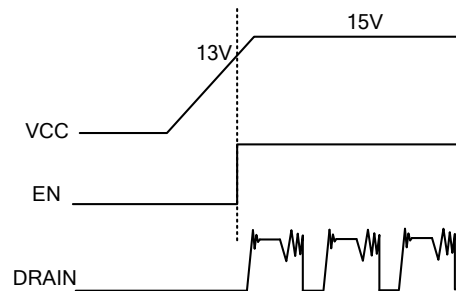

Fig.1 Start up sequence

Constant Current Control and Output Current Setup

Cycle-by-cycle current sense is offered in MT7968AL. The CS pin is connected to the current sense comparator, and the voltage on CS pin is compared with the internal 500mV reference voltage. The MOSFET is turned off when the voltage on the CS pin reaches the threshold.

The primary side peak current is given by:

$$I_{P_PK} = \frac{500}{R_{CS}} (mA)$$

Where, R_{CS} is the peak current sensing resistor (refer to the *Typical Application Circuit*). The comparator also includes a 500nS leading edge blanking time to block the transient noise.

The LED output current can be calculated by the following equation:

$$I_{LED} = \frac{I_{P_PK}}{4} \times \frac{N_P}{N_S} = \frac{500}{4 \times R_{CS}} \times \frac{N_P}{N_S} (mA)$$

Where, N_P is the turns of the primary winding, N_S is the turns of the secondary winding, I_{P_PK} is the primary side peak current. Shown in the above equation, the output current is determined only by the turns ratio of the transformer and the current sense resistor value, non-sensitive to the inductance of the transformer.

Switching Frequency

MT7968AL is designed to operate under discontinuous conduction mode and no external loop compensation is needed for stability. The maximum duty cycle is limited to 42%. It's highly recommended to limit the maximum switching frequency to be less than 100kHz and the minimum switching frequency to be more than 20kHz.

The switching frequency can be set by formula:

$$f_{SW} = \frac{N_P^2 \times V_{LED}}{8 \times N_S^2 \times L_p \times I_{LED}}$$

Where, N_P is the turns of the primary winding, N_S is the turns of the secondary winding, L_p is the transformer primary winding inductance. The transformer parameters should be properly designed to range the switching frequency between 40kHz to 80kHz.

LED Open Circuit Protection (OVP)

By detecting the secondary inductor demagnetization time, MT7968AL implements LED open circuit protection function.

Figure 2 shows the primary and secondary current waveform of transformer:

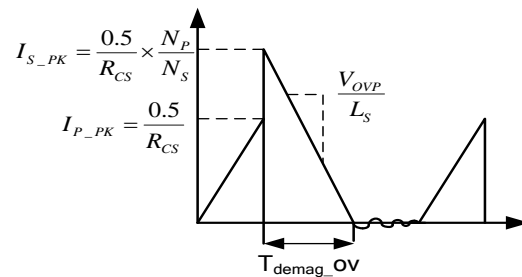

Fig.2 Primary and secondary current waveform of transformer

Refer to Fig 2, when LED is open-circuited, the secondary inductor demagnetization time is:

$$T_{demag_OV} = \frac{I_{S_PK}}{V_{OVP} / L_S} = \frac{L_S \times \frac{0.5}{R_{CS}} \times \frac{N_P}{N_S}}{V_{OVP}} (us)$$

Where, N_P is the turns of the primary winding, N_S is the turns of the secondary winding, L_S is the secondary inductance in uH, 0.5 is voltage threshold for V_{CS} detection in unit volt.

From the above formula, secondary inductor demagnetization time contains V_{OVP} voltage information. By detecting secondary inductor demagnetization time when LED is open-circuited, OVP protection is achieved:

$$V_{OVP} = \frac{L_S \times \frac{0.5}{R_{CS}} \times \frac{N_P}{N_S}}{T_{demag_OV}} (V)$$

A resistor R_{SET} at OVP pin (see Figure 3) sets the demagnetization time when LED is open-circuited :

$$T_{demag_OV} = 0.1 \times R_{SET} (us)$$

R_{SET} is in kΩ unit.

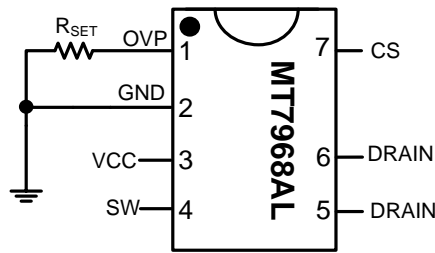

Fig.3 OVP pin schematic

The OVP voltage is:

$$V_{OVP} = 5 \times \frac{L_S}{R_{CS} \times R_{SET}} \times \frac{N_P}{N_S} \quad (\text{V})$$

Where, L_S is in μH unit, R_{CS} is in Ω unit, R_{SET} is in $\text{k}\Omega$ unit. Since the minimum T_{OFF} time is $2\mu\text{s}$, the resistance of R_{SET} can't be less than $20\text{k}\Omega$. The inductor's inductance variation affects the accuracy of OVP threshold. System design should take this into consideration. Certain margin for OVP threshold is needed. It's highly recommended to set the OVP threshold at least 1.3 times higher than the LED string voltage.

Over-Current Protection

MT7968AL immediately turns off the power MOSFET once the voltage at CS pin exceeds 500mV . This cycle by cycle current limitation scheme prevents the relevant components, such as power MOSFET, transformer, etc. from damage.

PCB Layout

The following rules should be followed in MT7968AL PCB layout:

Bypass Capacitor

The bypass capacitor on VCC pin should be placed as close as possible to the pin.

Ground Path

The ground path for capacitor C_{VCC} must connect to the chip ground directly, without any noise ground between them, such as SW capacitor ground, the power ground path for R_{CS} , etc.

Other small signal ground path should also connect to the chip ground pin. The chip ground and the SW capacitor ground should separately connect to the power ground path of current sense resistor R_{CS} . Keep the power ground path short and thick. Finally, all ground paths connect to the bulk capacitor C_{BUS} ground terminal.

OVP Pin and Its Trace

The OVP pin trace should be as short as possible. R_{SET} resistor (R_{OVP} in the following PCB Layout example) should be close to the OVP pin. OVP pin trace can't be close to the DRAIN and SW pin and related traces. Ground line can be used to shield the OVP pin and traces. This shielding ground should bare copper. Refer to the following PCB Layout example.

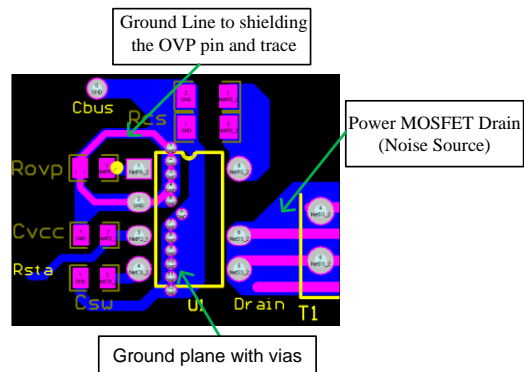

The Area of Power Loop

The area of main current loop should be as small as possible to reduce EMI radiation, such as the primary current loop, the snubber circuit and the secondary rectifying loop.

DRAIN pin

To increase the copper area of the drain terminal for better thermal dissipation. But drain terminal is the major noise source of the system. Too large copper area may compromise noise reduction.

PACKAGE INFORMATION

DIP-7 (7-Lead Dual In-Line)

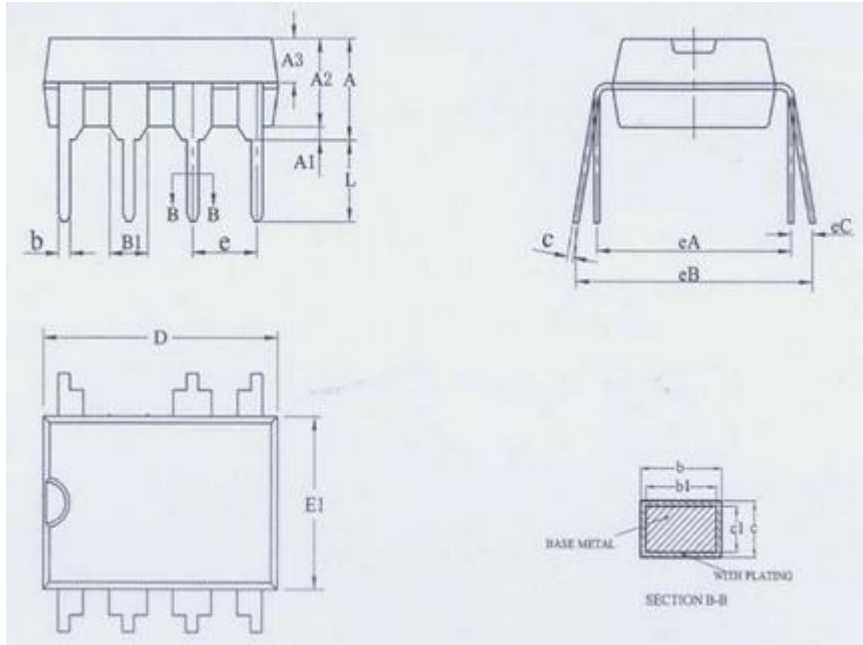

SYMBOL	MILLIMETER		
	MIN	NOM	MAX
A	3.60	3.80	4.00
A1	0.51	—	—
A2	3.00	3.30	3.40
A3	1.55	1.60	1.65
b	0.44	—	0.53
b1	0.43	0.46	0.48
B1	1.52BSC		
c	0.24	—	0.32
e1	0.23	0.25	0.27
D	9.05	9.25	9.45
E1	6.15	6.35	6.55
e	2.54BSC		
eA	7.62BSC		
eB	7.62	—	9.30
eC	0	—	0.84
L	3.00	—	—
L/F载体尺寸 (mil)	80*80		

Important Notice

- Maxic Technology Corporation (Maxic) reserve the right to make correction, modifications, enhancements, improvements and other changes to its products and services at any time and to discontinue any product or service without notice. Customers should obtain the latest relevant information before placing orders and should verify that such information is current and complete. All products are sold subject to Maxic’s terms and conditions of sale supplied at the time of order acknowledgement.
- Reproduction, copying, transferring, reprinting this paper without Maxic’s written permission is prohibited.
- Maxic is not responsible or liable for customer product design by using Maxic components. To minimize the risks and associated with customer products and applications, customers should provide adequate design and operating safeguards and consult Maxic’s sales department.