

DESCRIPTION

MT7601 is a linear constant - current LED driver, used in non-isolated 110VAC / 220VAC directly drive of LED lighting.

The MT7601 integrates 500V power MOSFET. No electrolytic capacitor, Inductor and transformer are needed. Low BOM cost is achieved. The whole driver system can be integrated into the LED lighting module. As an integrated Lighting Engine, it can be driven by AC line directly.

The LED string current can be flexibly set by external sense resistor, range from 10mA ~ 60mA. More than one MT7601 can be used in parallel to support even larger LED current.

FEATURES

- Linear constant - current LED driver
- High precision constant current output.
- Build in 500V power MOSFET
- Less peripheral components
- Directly integrated into LED lighting Engine
- Support TRIAC dimming
- Support line voltage compensation
- Over temperature protection
- Available in SOP8 package

APPLICATION

- LED fluorescent light, panel light
- LED bulb light, decorative light
- Other compact LED Lighting Product

Typical Application Circuit

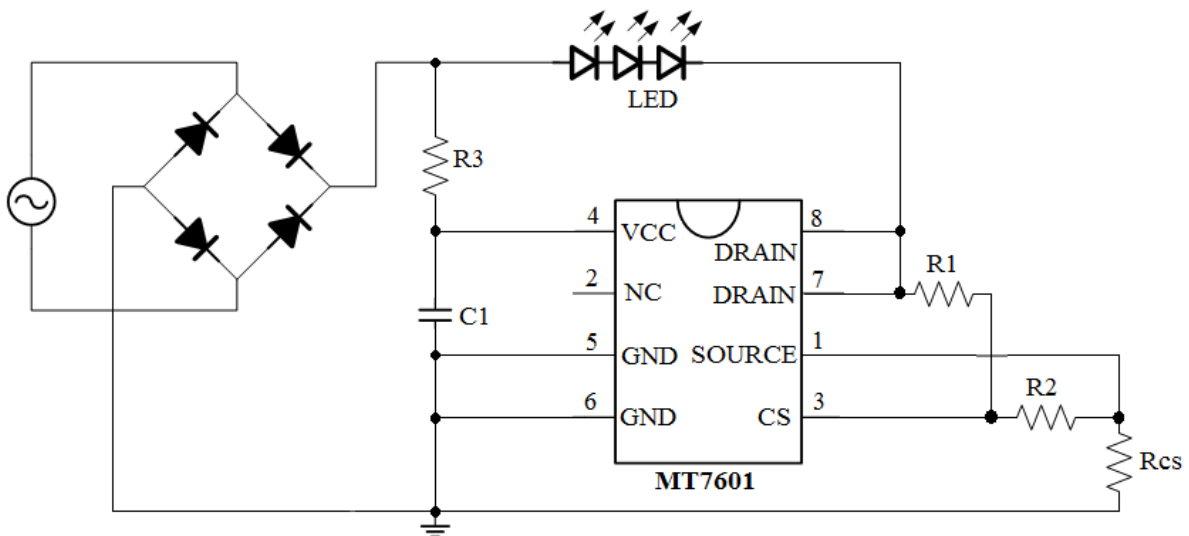

ABSOLUTE MAXIMUM RATINGS

VCC	-0.3V ~ 20V
CS	-0.3V ~ 6V
DRAIN	-0.3V ~ 500V
Storage Temperature	-55°C ~ 150°C
Junction Temperature (Tj)	150°C

RECOMMENDED OPERATING CONDITIONS

Supply voltage VCC	15V
Operating Temperature	-40°C ~ 105°C

THERMAL RESISTANCE

Case to ambient (R _{CA})	128°C/W
------------------------------------	---------

PIN CONFIGURATIONS

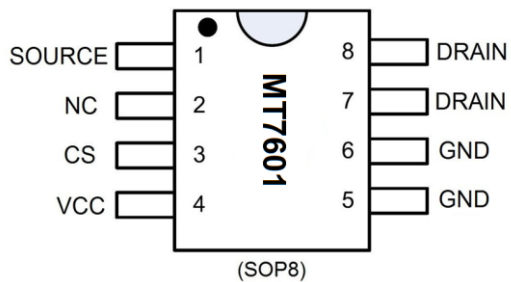

Chip Mark

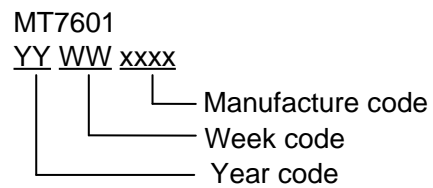

PIN DESCRIPTION

Name	Pin No	Description
SOURCE	1	Internal power MOS source terminal.
NC	2	No Connection
CS	3	Current sense pin. A sense resistor (R _{cs}) is connected between CS and GND
VCC	4	Power supply
GND	5, 6	Ground
DRAIN	7, 8	Internal power MOS drain terminal. Connected to LED string.

ELECTRICAL CHARACTERISTICS

(Test conditions: $V_{DD}=15V$, $T_A=25^{\circ}C$ unless otherwise stated)

Symbol	Parameter		Min	Typ	Max	Unit
Start-up & Power supply (VCC pin)						
I_{START}	Start-up Current			30		μA
UVLO	Under Voltage Lockout of V_{CC}	V_{CC} Pin ramp down		7		V
V_{START}	Start-up Voltage	V_{CC} Pin ramp up		9		V
$V_{CC-CLAMP}$	VCC clamp voltage	$I_{CC}=10mA$		15		V
Operation Current						
I_Q	Operation Current			300		μA
Current Sense						
V_{REF}	Internal reference voltage		490	500	510	mV
Over Temperature Protection						
OTP	Over temperature protection threshold			155		$^{\circ}C$
	Over temperature protection release hysteresis			20		$^{\circ}C$

BLOCK DIAGRAM

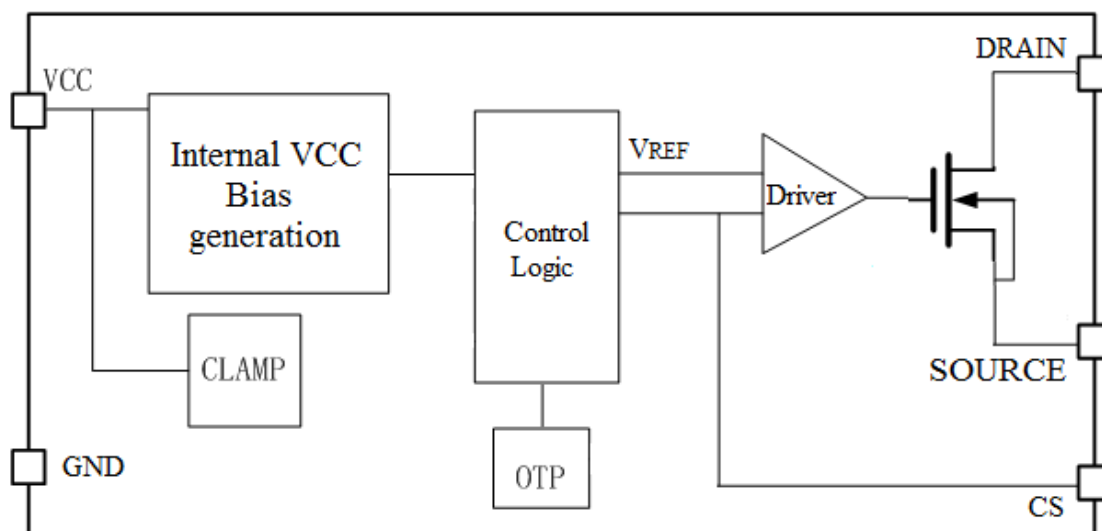

APPLICATION INFORMATION

MT7601 is a linear constant - current LED driver, integrated with 500V power MOSFET. Accurate LED output current is achieved with minimized external components.

Start Up

During start-up, VCC is charged through a start-up resistor. As VCC reaches 9V, the control logic starts to work. As VCC continue increases, the chip will clamp VCC at 15V, as shown in Fig.1.

MT7601 shuts down as VCC falls below 7V.

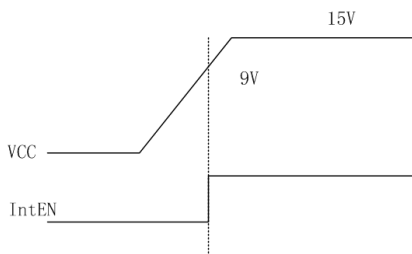

Fig.1 Start up sequence

Output Current and Voltage Determination

It's important to determine the LED voltage and current when uses MT7601. As MT7601 is a linear buck LED driver IC, the peak value of the rectified input voltage must be greater than output LED voltage.

Refer to Fig.2, MT7601 automatically turns on the LED string following the input sine wave. When the input voltage rises and reaches the LED conducting voltage V_{LED} , LED string turns on. Since then, the input voltage continues rising, the LED string voltage keeps stable, the internal MOSFET bears the superfluous voltage drop. If the input voltage drops, the procedure is reversed. So if the LED voltage is too high, the turn on time for LED string is short. If the LED voltage is too low, the system efficiency will be reduced. Recommend to choose about 120V high-voltage LED string in 110VAC applications,

to choose about 260V high-voltage LED string in 220VAC applications. It can be adjusted according to actual application.

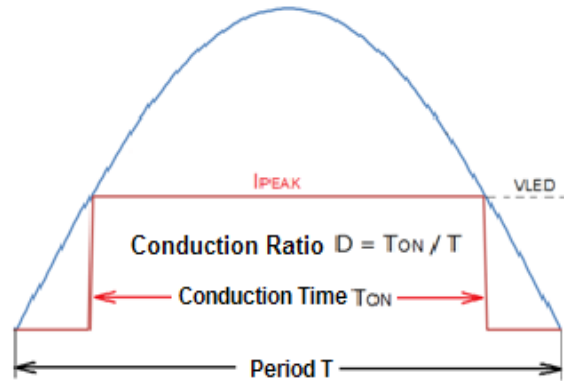

Fig.2 LED conduction procedure

Sense Resistor Settings

Output current be set by the sense resistor R_{CS} . MT7601 generates a control signal by comparing the sense resistor R_{CS} voltage and internal reference voltage V_{REF} (500mV), LED constant current output is achieved.

Peak current of LED light string:

$$I_{PAEK} = \frac{V_{REF}}{R_{CS}} = \frac{500mV}{R_{CS}} \quad (1)$$

Fig.2 shows, MT7601 actually controls the peak current during the LED turn on period.

There are two cases in real application:

- 1) There is no large electrolytic capacitor behind the rectifier bridge, as shown in Fig.2. At the valley, the input voltage is lower than LED conduction voltage, output current is zero. When the input voltage is higher than the LED string voltage, output current is I_{PEAK} . So, the LED string current is discontinuous. Finally, the I_{LED} is LED string average current.

$$I_{LED} = I_{PEAK} \times D \quad (2)$$

Where D is the LED string turn-on ratio. In

general, $D \approx 0.5$, so $I_{LED} \approx 0.5 \times I_{PEAK}$.

The final LED average current needs to fine tune according to the measured results. In this case, the system power factor (PF) can reach more than 0.9. But the LED output current will increase with the input voltage.

- 2) There is a large electrolytic capacitor behind the rectifier bridge. After rectifying, the line voltage substantially closes to DC voltage. So, the LED output current equals the peak current, $I_{LED} = I_{PEAK}$, as calculated in Equation (1). In this case, the output current is stable. But power factor is relatively lower.

Power Consumption and Heat Dissipation

The voltage difference between input voltage and output LED voltage can generate power consumption, which is all undertaken by MT7601 internal power MOSFET. So, the LED string voltage and input voltage range should be properly configured to guarantee the power consumption of MT7601 less than 1W, or use good heat sink to lower the temperature. Aluminum substrate PCB is recommended for better heat dissipation.

Over Temperature Protection

MT7601 shuts down as the internal temperature reaches the OTP (Over-Temperature Protection) threshold. When the temperature goes down about 20 °C hysteresis, it will resume.

LED Open Circuit and Short Circuit Protection

When the LED string is open-circuited, MT7601

system enters standby mode. When the LED string is short-circuited, the output current $I_{PAEK} = \frac{VREF}{Rcs} = \frac{500mV}{Rcs}$ keeps stable, so the IC temperature is increasing rapidly, as all the line voltage drops across the MT7601 internal power MOSFET. The system enter into Over Temperature Protection (OTP) status, the current cuts off automatically. Until the temperature drops, the current resume.

Line Voltage Compensation Circuit

MT7601 control the peak current during the LED turns on. When the capacitor after the rectifier bridge is small (high PFC applications), the LED turn-on ratio varies with the input voltage. The LED average output current will increase as the input voltage increases. In this case, the line voltage compensation circuit can be added, refer to Fig. 3. Usually, R1 = 510Kohm, R2 is about 1.2Kohm. the bigger the R2 is, the stronger the compensation is. By adjusting R2 value, the variation of the LED output power can be minimized. C2 is used to stabilize the system loop and reduce EMI (electromagnetic interference). Its capacitance normally is 22nF.

Increases LED output current

MT7601 can support the peak LED current at about 60mA. If the current is too large, the chip temperature rises rapidly, and the system enter into the Over-Temperature Protection (OTP) status. If peak LED current is greater than 60mA, more than one MT7601 can be used in parallel.

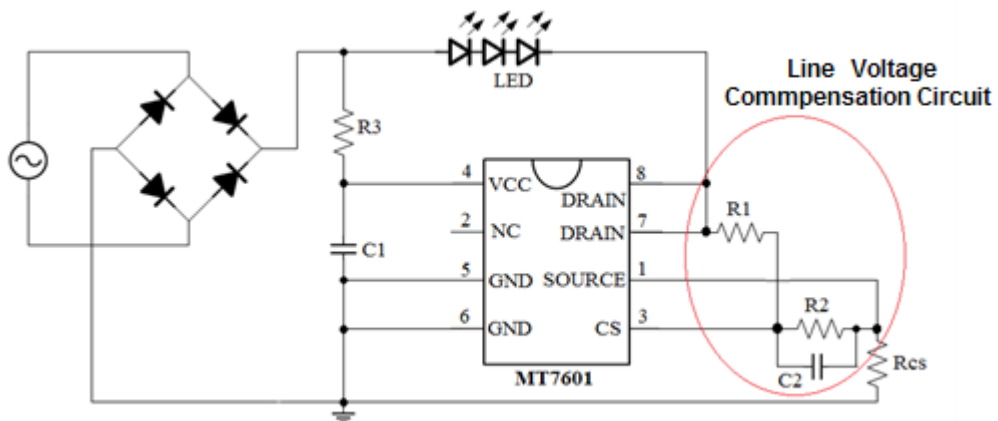
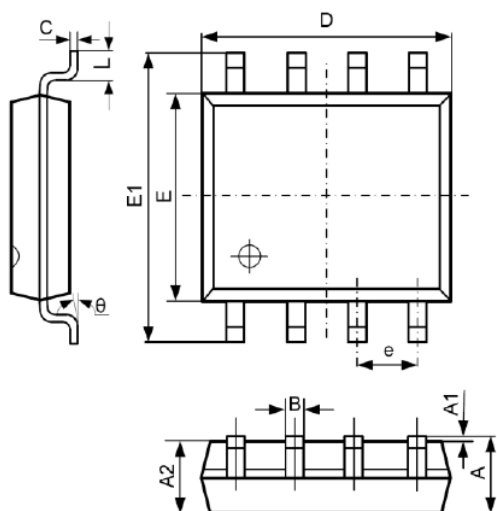

Fig. 3 Application with line voltage compensation

PACKAGE INFORMATION

SOP-8 PACKAGE OUTLINE AND DIMENSIONS



SYMBOL	DIMENSION IN MILLIMETERS		DIMENSION IN INCHES	
	MIN	MAX	MIN	MAX
A	1.350	1.750	0.053	0.069
A1	0.100	0.250	0.004	0.010
A2	1.350	1.550	0.053	0.061
B	0.330	0.510	0.013	0.020
C	0.190	0.250	0.007	0.010
D	4.700	5.100	0.185	0.201
E	3.800	4.000	0.150	0.157
E1	5.800	6.300	0.228	0.248
e	1.270 TYP		0.050 TYP	
L	0.400	1.270	0.016	0.050
theta	0° - 8°		0° - 8°	

Important Notice

- Maxic Technology Corporation (Maxic) reserve the right to make correction, modifications, enhancements, improvements and other changes to its products and services at any time and to discontinue any product or service with notice. Customers should obtain the latest relevant information before placing orders and should verify that such information is current and complete. All products are sold subject to Maxic's terms and conditions of sale supplied at the time of order acknowledgement.
- Reproduction, copying, transferring, reprinting this paper without Maxic's written permission is prohibited.
- Maxic is not responsible or liable for customer product design by using Maxic components. To minimize the risks and associated with customer products and applications, customers should provide adequate design and operating safeguards and consult Maxic's sales department.

For detail products information and sample requests, please contact:

Maxic Technology Corporation (Beijing Office)

1006, Crown Plaza Office Tower, No106, ZhiChun Road, Hai Dian District, Beijing, China, 100086

Tel: 86-10-62662828

Fax: 86-10-62662951

Maxic Technology Coporation (Shenzhen office)

Room 1115, Qinghai Building, No.7043 North Ring Road, Futian District, Shenzhen, P.C. 518000

Tel: 86-755-83021778

Fax: 86-755-83021336

Maxic Technology Corporation (Suzhou Office)

B-503, #3 Chuangye Park, 328 Xinghu Street, Indurial Park, Suzhou, 215021

Tel: 86-512-62958262

Fax: 86-512-62958262

Maxic Technology Corporation(Indian office)

50-B, Bhatia Colony, Ballabgarh-121004, Faridabad(INDIA)

E-mail: India@maxictech.com

Web: www.maxictech.com

E-mail: sales@maxictech.com, info@maxictech.com